

Industrial Sensor for Harsh Environment (Throttle Position/Through Hole)



FEATURES

- Fully “sealed” robust package
- Electrical connection: AMP superseal 1.5 series integrated connector
- Through hole D drive
- Mountable on both faces
- Reference index indent
- Return spring option
- Standard electrical resistance (and custom options)

The Model 970 has been specifically developed to operate and maintain high functional performance under harsh environmental conditions. These include: extremes of temperature, continuous vibration, chemical exposure and water immersion. This universal device is fully sealed to ingress protection IP67 providing high mechanical durability and long electrical life. This industrial sensor is suitable for a different variety of applications within the automotive, medical and robotic industries.

ELECTRICAL SPECIFICIATONS	
PARAMETER	
Standard Resistance	5 kΩ, ± 20 °C
Resistance Tolerance	± 30 %
Linearity (Absolute)	± 2 %
Electrical Angle	Standard version 200° continuous rotation version 346°
Output Smoothness	0.5 %
Maximum Voltage	30.0 V _{DC}
Temperature Coefficient of Resistance	600 ppm/°C

MECHANICAL SPECIFICATIONS	
PARAMETER	
Rotation (Options)	190° with mechanical stops 190 with mechanical stops and return spring 360 continuous
Stop Strength	680 mNm minimum
Fixed Torque (Recommended)	2 to 3 Nm
Spring Torque	Minimum return 20 Nmm Maximum wind-up 115 Nmm
Mounting Pitch	41 mm

ORDERING INFORMATION/DESCRIPTION		
970 - 1036 MODEL	0000 VERSION 0000 Without spring return 0001 With spring return 0002 Continuous rotation	BO100 PACKAGING Box of 100 pieces

SAP PART NUMBERING GUIDELINES			
970 MODEL	1036 STYLE	0000 CONFIGURATION	B30 PACKAGING



DIMENSIONS in inches (millimeters)

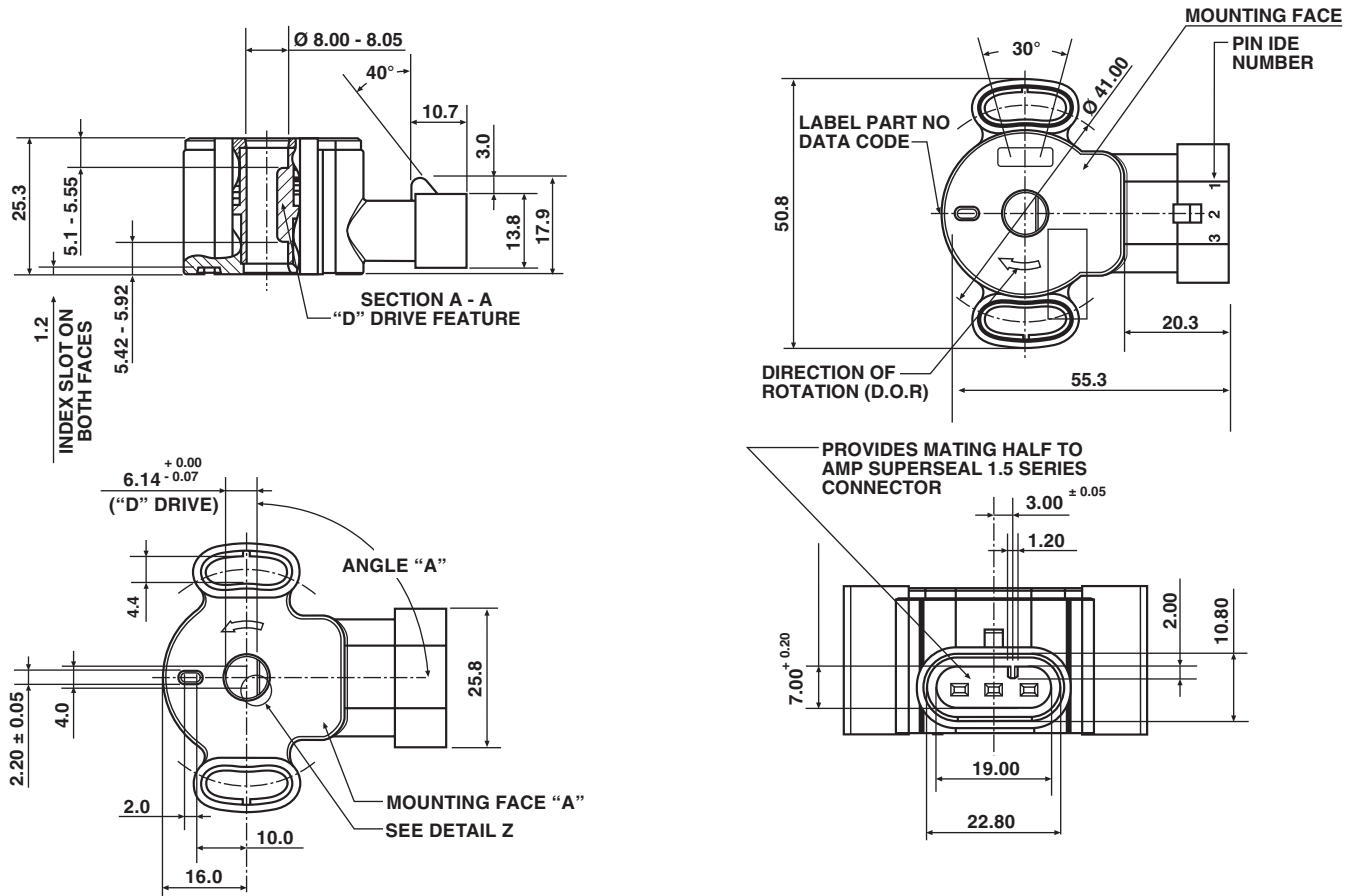

ENVIRONMENTAL SPECIFICATIONS	
PARAMETER	
Vibration	15 g thru 2000 Hz
Shock	50 g
Rotational Life	5 000 000 full cycles 10 000 000 dither cycles (second rotation)
Load Life	900 h
Temperature Range	- 40 °C to + 130 °C
Sealing	IP67
Humidity	96 % at 40 °C (500 h)
Salt Spray	5 % solution at 40 °C (300 h)

MARKING	
Unit Identification	Manufacturer's name and model number, resistance value, tolerance, data code and terminal identification



Disclaimer

All product specifications and data are subject to change without notice.

Vishay Intertechnology, Inc., its affiliates, agents, and employees, and all persons acting on its or their behalf (collectively, "Vishay"), disclaim any and all liability for any errors, inaccuracies or incompleteness contained herein or in any other disclosure relating to any product.

Vishay disclaims any and all liability arising out of the use or application of any product described herein or of any information provided herein to the maximum extent permitted by law. The product specifications do not expand or otherwise modify Vishay's terms and conditions of purchase, including but not limited to the warranty expressed therein, which apply to these products.

No license, express or implied, by estoppel or otherwise, to any intellectual property rights is granted by this document or by any conduct of Vishay.

The products shown herein are not designed for use in medical, life-saving, or life-sustaining applications unless otherwise expressly indicated. Customers using or selling Vishay products not expressly indicated for use in such applications do so entirely at their own risk and agree to fully indemnify Vishay for any damages arising or resulting from such use or sale. Please contact authorized Vishay personnel to obtain written terms and conditions regarding products designed for such applications.

Product names and markings noted herein may be trademarks of their respective owners.